

EauFlow



Purified clinical water on tap



EauFlow 505 (Hard Water 12L Tap Option)

Supplier code EY5505HW

Installation Manual



Thank you for selecting an EauFlow Reverse Osmosis (RO) Machine. In order to fully optimise the use of your system, please read this instruction manual carefully before installation.

Fitting Instructions

EauFlow 505

Reverse Osmosis Unit
(Medium/Hard Water)

(Supplier Code: EY5505HW)

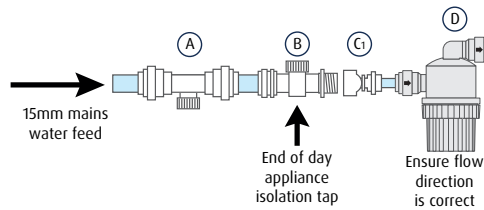

Supplier codes (see fitting instructions)		Dispatched
A) Non return valve	EY20110	<input type="checkbox"/>
B) Appliance tap	EY20111	<input type="checkbox"/>
C) 3/4" to 1/4" BSP (x3)	EY20112	<input type="checkbox"/>
D) RO filter strainer	EY20334	<input type="checkbox"/>
E) RO unit	EY5505HW	<input type="checkbox"/>
F) Tank ball valve	EY20127	<input type="checkbox"/>
G) Storage tank 12L water capacity	EYST12	<input type="checkbox"/> *
H) Branch stem tee 1/4"	EY20137	<input type="checkbox"/>
I) Dispensing valve (x4)	EY20006	<input type="checkbox"/>
J) Deioniser cartridge	EY30810	<input type="checkbox"/>
K) Counter-top tap	EY20300	<input type="checkbox"/> *
L) TDS meter (Inline)	EY20155	<input type="checkbox"/>
M) Drain connector/air gap	EY20336	<input type="checkbox"/>
N) Drain saddle valve	EY20065	<input type="checkbox"/>
O) Long tail Elbow connector x 4	EY20122	<input type="checkbox"/>
P) 1/4"(6.2mm) tube - 10m	EY20008	<input type="checkbox"/>
Total Components = 24		

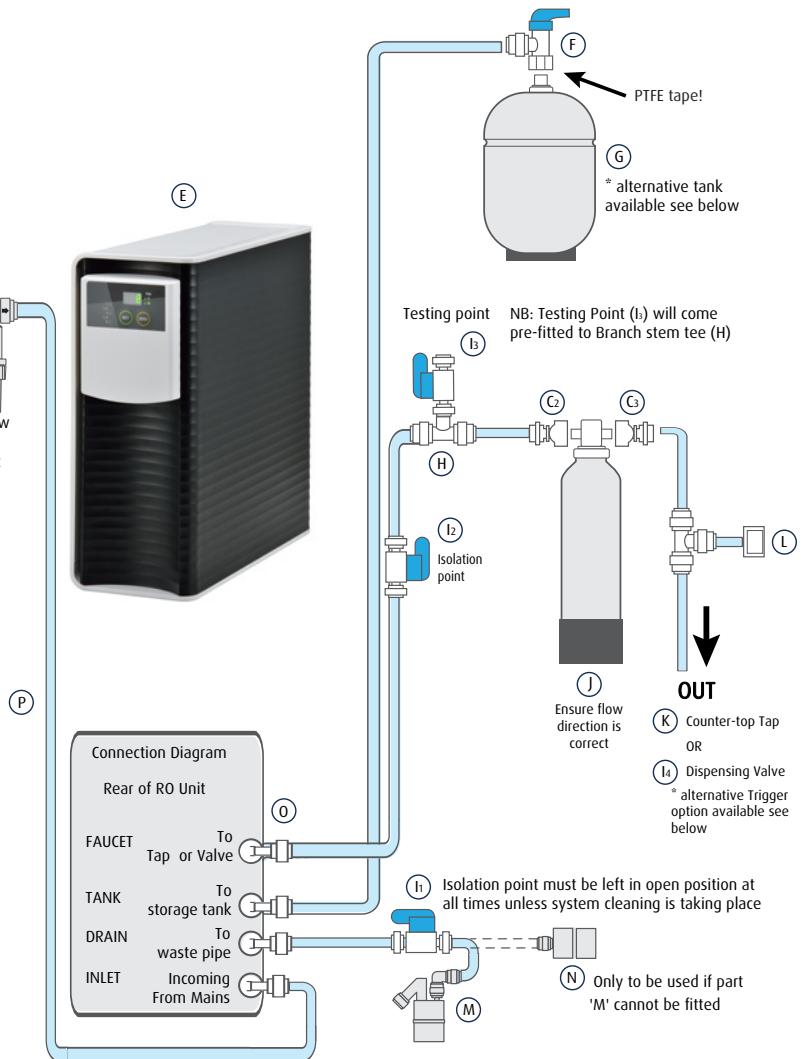

*A 22L capacity tank is available (supplier code EYST22). This larger tank can be used as a replacement for the 12L tank or can be added as an additional secondary tank using a 'T' Piece connector (supplier code EY20123) to increase water capacity output.*Trigger Nozzle set (EY20367) can be fitted instead of Counter-top Tap or dispensing Valve.

Picking date: _____ Picked by: _____

Important Installation Details 2 Yr Extended Warranty only valid if the warranty card and a copy of this fitting sheet are returned to CleanCert offices by post and RO has been fitted by a CleanCert trained engineer

Installation date:	Serial number: (back of unit) 20.....-EY505-.....HW
Engineers name and contact details:	
Practice name:	Has the 'Basic maintenance' training been explained to staff? (Details)
Practice phone:	
Practice email:	



Purchase Order no (if applicable): _____

Warning!

Please observe the following recommendation:

If you are fitting an Eauflow Reverse Osmosis (RO) unit where the mains water feed:

- 1) Comes from a cold water 'storage' tank that is not routinely maintained
OR
- 2) Has any plumbing deadlegs in the plumbing between the stop cock in the road and the RO unit plumbing point.

We recommend fitting a bacterial inline water filter and digital water flow meter before the RO



Further details on these can be found on page 6 under 'Additional RO equipment'.

Three sizes available

Failure to observe these conditions will result in bacterial contamination of your EauFlow RO system that could cause serious human health issues if left unchecked.



CleanCert 2-in-1 dental waterline disinfectant (SUPPLIER CODE BFCEP50)

To help keep your dental waterlines clear of bacteria and biofilm, we recommend using CleanCert 2-in-1 Dental Waterline Disinfectant with 2 protocols in one bottle:

- Continuous dosing at 2% (20ml in a 1L chair bottle topped up with 980ml fresh RO water)
- Periodic shock treatment (typically 90% faster bacteria elimination contact time than competitors)

CleanCert is available from selected dental wholesalers or more information is available on our website by scanning here:



NB: CleanCert should NOT be used in Autoclaves

Installation

Connection and filling of EauFlow RO system

Mains Connection Diagram

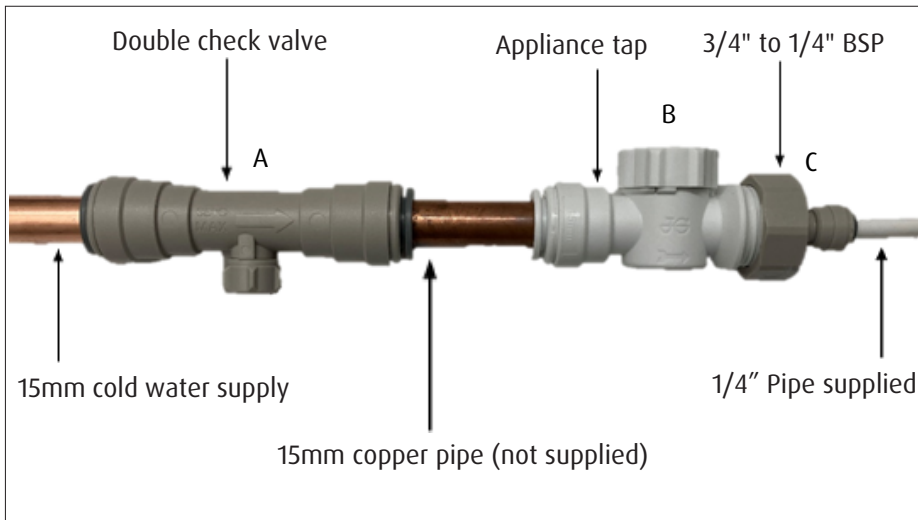

1. Connect all components as shown on the 'Fitting Instructions' sheet on page 1 (Items A, B and C from fitting sheet shown in above picture)
2. Ensure valve on top of storage tank is in 'off' position (90 degrees to tubing) and dispensing point (valve or counter-top tap) is 'open'
3. Connect the electricity and water supply to the RO and turn on
4. Allow water to flush through cartridges and run from dispensing point (valve or counter-top tap) for 5 minutes down the drain
5. Now close the dispensing point (valve or counter-top tap) and open the valve on top of storage tank (in line with tubing)
6. Allow storage tank to fill (around 60-90 minutes for a 12L water capacity tank)
7. Do not use first tank of water - allow to run down drain by opening dispensing point (valve or counter top tap)
8. Allow tank to refill - system is ready for use.

NB: A 22L capacity tank is available (supplier code EYST22). This larger tank can be used as a replacement for the 12L supplied tank or can be added as an additional secondary tank using a 'T' Piece connector (supplier code EY20123) to increase water capacity output.

Tank technical details:

EYST12 12L water capacity, size 26 x 44 cm (including tank ball valve), weight: 4kg empty 15kg full.

EYST22 22L water capacity, size 38 x 58 cm (full height in stand - tank to be fitted inverted to achieve this height), weight: 11kg empty 34kg full.

Maintenance

Changing the Filter Cartridges

IMPORTANT! There are 5 filters in the machine to change, 3 after removal of the black side panel and 2 after removal of the white side panel

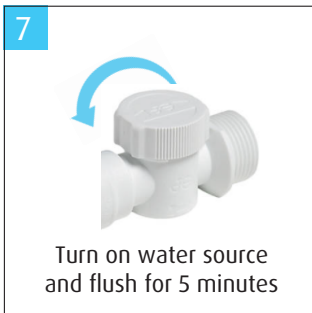
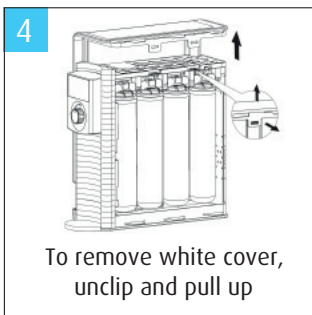
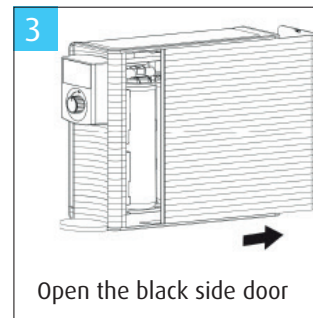

The following periodic maintenance is recommended so your system will provide an uninterrupted supply of purified water:

Cartridge Filter	Service life
Green stage 1 - Pre-filter (Sediment)	Every 9-12 months
Blue stage 2 - Pre-filter (Activated Carbon)	Every 9-12 months
Red stage 3 - Pre-filter (Carbon block)	Every 9-12 months
Purple stage 4 - R/O membrane	Every 9-12 months
Yellow stage 5 - Deioniser Cartridge	Every 9-12 months

HARD WATER AREA (greater than 250ppm CaCO₃) - please ensure you add the post-RO large blue external deioniser cartridge, to ensure an uninterrupted supply of purified water for your practice.

Common Troubleshooting Issues

Issues, reasons and resolutions

ISSUE	REASON	RESOLUTION
999 appears in display screen	Cartridge warning lights have been left flashing	To remove it: a) Press 'Set' button for 3 seconds b) Then Press 'Zero' button for 3 seconds c) Unplug the RO unit <u>within 1 second</u> d) Turn on again <u>within 10 seconds</u> . The '999' should disappear.
RO Machine bleeping and number light flashing	Cartridge needs changing	a) Turn off water coming into RO and change all 5 cartridges. b) Press zero button for 5 seconds until machine bleeps
'!' light flashing	TDS level in water too high	a) Valve to drain may have been turned off - turn on and flush 2 x tanks of water b) If it has been over 9-12 months since last changing cartridges/installed machine then change all 5 cartridges c) If it has been less than 9 months since you changed cartridges, then you need an additional blue Di cartridge EY30810 (plus inline TDS meter EY20155) between RO and dispensing valve/tap. Contact your rep for details.
'Power' light flashing	Electricity fault	a) Change fuse in plug Or b) You need a new PCB board
5 lights flashing red = leak detector alarm	Water detected in base of unit. Normally caused by not turning off water before changing cartridges, an internal leak or condensation of cold water entering filters	a) Turn off RO unit from the mains water and electric, then remove side panels (slide back black panel, undo white clips and lift up white panel) b) Ensure filter cartridges are fully secured and not leaking c) Mop up water in base of unit and ensure it is fully dry. You might also need to turn RO unit on its side to get rid of any excess water in the base. Have a cloth underneath for this purpose d) Pull out black probe on front LHS (black wire connected to base), wipe with a cloth and replace. Ensure chamber is fully dry before replacing probe e) Press zero for 2 seconds to reset the machine
SRC showing on display	No water input	a) Ensure mains water feed in pipe is connected correctly on the unit b) Ensure valves and taps to mains input are turned to 'on'
FSH showing on display	System is flushing water through the filters	a) Wait for the system to finish the flushing process. This process removes air from newly installed filters

Additional RO Equipment

RO Cleaning Kit

UK HTM01/05 - sec 6.50: 'Specialist items of equipment may require cleaning and decontamination processes that are purpose designed'.



Under normal working conditions, your EauFlow Reverse Osmosis (RO) water filter machine will not have any microbiological matter (bacteria) growing inside it. Unexpected extraneous conditions (eg. temporary local water treatment problems, static water due to lack of use, poor maintenance etc.) can result in bacteria growing inside your RO unit. Left unchecked, this bacteria can be detrimental to health in a clinical application and needs removing.

We recommend QUARTERLY testing of the water dispensed from your RO unit with a TVC (total viable count) dipslide (supplier code BFCDS10) to check whether bacteria has grown inside the RO unit.

In the unlikely event of your microbiological test detecting bacteria, we recommend firstly that you contact us to aid in the investigation of why the bacterial test has failed.

If cleaning is suggested by us after all other options have been investigated, a simple 'RO cleaning kit' (supplier code EY90200-ST) is available which contains components needed to clean the RO system. In addition to the kit, you will need a 5L bottle of CleanCert 2-in-1 dental waterline disinfectant (supplier code BFCEP50). Both are available from selected dental wholesalers.

Video instructions can be found on: [YouTube-CleanCert](#) (search for your RO model)

Bacterial inline water filter

Recommended for mains water supplies where the decon room is situated above the first floor or where buildings are shared with other occupants creating a possible source of residual bacterial contamination.



Easily installed with quick-fit push fittings onto 6.2mm RO tubing and comes in three sizes depending on water usage:

- 3000 Litre capacity for 1-2 chair practices (EY30220)
- 13000 Litre capacity for 3-5 chair practices (EY30221)
- 56000 Litre capacity for 6+ chair practices (EY30222)

It is also a requirement to fit a digital water flow meter (EY20117) with the water filter on first installation so that it is known when the filter capacity is reached.



For further enquiries please contact:

Tec-Safe
Unit 16b Wyndham Business Place, Grosvenor Drive,
Tisbury, Wiltshire SP3 6GS UK

Email: technical@tec-safe.com

Phone: 08443 511115



EauFlow

Purified clinical water on tap

BASIC MAINTENANCE

Reverse Osmosis Water System

Installation Date:

Serial Number:

You will have been issued with a flow diagram with this maintenance guide to be affixed to a suitable location near the RO system which will help in the day-to-day maintenance ensuring an uninterrupted supply of purified water. Please refer to this for basic maintenance solutions. For further maintenance guidance please view the steps below.

1) DAILY

Start of the day:

- Run waterline for 30 seconds to purge stale water from tubing
- Check the RO unit for any flashing lights or beeping from the digital display – the TDS level needs to be below 10 (‘inorganic’ reading)
- Check your RO unit for any water leaks – report to manager immediately

End of the day:

- Turn OFF mains water feed to the RO – this will prevent any unexpected leaks when surgery is empty



2) QUARTERLY

Test your water quality for bacterial contamination (‘organic’ reading) with TVC dipslides

- Run the RO water for 30 seconds (dispensing valve or tap)
- Using a TVC dipslide, remove cap, dip in water for 10 seconds, replace cap and allow to incubate for 1 week
- Fill in the log sheet
- If a dipslide shows any red dots, report to your manager or contact: technical@tec-safe.com

3) ANNUALLY

Under normal circumstances, we recommend changing all cartridges once per annum

- Change all 5 filter cartridges on the RO unit
- Change large blue DI cartridge (Hard water model only)

4) HOW TO CHANGE THE 5 RO FILTER CARTRIDGES

This process can be easily completed in 30 seconds without tools.

- a) Turn off mains water coming into the RO on the appliance tap (as you would at the end of the day)
- b) Turn off valve on top of RO storage tank, so it's 90 degrees to tubing
- c) Open dispensing point (valve or tap) to release any water in the system
- d) Now open RO unit by sliding back black plastic panel and then release white panel with 2 clips at the top on the same side
- e) Have a piece of cloth on hand to mop up up any residual water in the RO
- f) Remove the old filters from the RO unit by simply twisting the filter anti-clockwise, taking note of which number cartridge goes in each slot – it is important not to mix them up! (green = 1 sediment, blue = 2 carbon, red = 3 carbon, purple = 4 membrane, yellow = 5 Di)
- g) Unwrap the new filter, remove the black lid and insert the new cartridge by simply twisting clockwise onto the unit
- h) Ensure RO storage tank valve is still closed
- i) Turn the mains water on
- j) Flush through the cartridges for 1 minute
- k) Open tank valve and let the tank fill up (typically 60–90mins for a 12lt tank)



5) HOW TO CHANGE BLUE DI CARTRIDGE (EY30810)

- 1) Turn off storage tank valve
- 2) Turn off mains water coming into RO unit
- 3) Open tap and empty RO and Di of any residual water
- 4) Finally disconnect push-fittings on blue Di tank (by pushing collar in and pulling pipe out at the same time)
- 5) Replace with new cartridge. Ensure tubing is pushed in tightly and flow direction is correct by checking water flows in direction of arrows on top of Blue DI. **IMPORTANT - Do not remove red clips!**

6) HOW TO RESET ANY FLASHING LIGHTS ON THE TDS DISPLAY

Press Zero button for 2 seconds

7) HOW TO DECONTAMINATE THE RO SYSTEM IF BACTERIA READINGS ARE SHOWING ON DIPSLIDE

Firstly contact technical@tec-safe.com for further investigation

If cleaning is suggested, video instructions can be found on: **YouTube-CleanCert** (search for your RO model)

If you have any further questions please contact the technical team on:

08443 511115 / technical@tec-safe.com

www.tec-safe.com

Tec-Safe, Unit 16b, Wyndham Business Place, Grosvenor Drive, Tisbury, Wilts. SP3 6GS

Page 8

PP201-1 v5 04/01/23



WATER MONITORING LOG

Reverse Osmosis (RO) System

Date of installation:

Thank-you for buying a CleanCert RO system.

We recommend you carry out ongoing simple monitoring on your RO system, to provide you with an uninterrupted supply of purified water for autoclaves and dental chairs.

Water supply issues that arise in your RO output water fall into 2 categories: 'organic' (bacteria mainly) and 'inorganic' (limescale and nitrates mainly).

MONTHLY WATER MONITORING LOG SHEET

Monitoring 'Inorganic' levels - Total Dissolved Solids (TDS)

Record the number in the digital display on your TDS meter; this reading should remain below 10ppm to stop your autoclave rejecting the water. Inorganic materials are 'non live' impurities found in all potable (tap) water. Please use the following log to keep a record of your TDS readings:

Instructions

Let water run for 30 seconds before taking the reading on the TDS display:

- Soft water model (EY505) - on the built-in TDS display on the RO unit
- Hard water model (EY5505) - reading on the inline TDS meter after the blue cartridge

Year:	TDS Meter Reading	Filters Replaced?	Completed By
January			
February			
March			
April			
May			
June			
July			
August			
September			
October			
November			
December			

If you have any further questions please contact the technical team on: 08443 51115 or email technical@tec-safe.com



QUARTERLY WATER MONITORING LOG SHEET

Monitoring 'Organic' levels - (bacteria)

We recommend using a TVC dipslide to proactively monitor bacteria in your RO unit.

Instructions:

- Allow RO water to run for 30 seconds
- Remove cap and insert dipslide in water for 10 seconds. Replace cap
- Incubate for 1 week to get an accurate reading
- Repeat quarterly

Date	Test Carried Out on waterline or RO?	Dipslide Batch No.	Result	Action To Follow?

If you have a positive reading on your dipslide:

1. Empty RO tank completely and allow to fill up. Then retake dipslide test
2. Ensure the water feeding your RO system is not coming from a cold water storage tank in the loft, or has any plumbing 'dead legs' on it
3. Contact technical@tec-safe.com for assistance, sending images of your dipslide readings
4. If cleaning is suggested, video instructions can be found on: [YouTube-CleanCert](#) (search for your RO model)

If you have any further questions please contact the technical team on:

08443 511115 or email technical@tec-safe.com

www.tec-safe.com



Have you explored our infection control products?

CleanCert

The advanced 2 in 1 dental waterline disinfectant for complete protection

Scan below for further information on CleanCert



OraWize+

The Powerful dental rinse for the complete dental journey, before, after and during treatment

Scan below for further information on OraWize+



OptiZil

Eco-friendly clinical disinfectant for ultimate performance

Scan below for further information on OptiZil



For further product information please contact:
sales@tec-safe.com

www.tec-safe.com



Unit 16B Grosvenor Drive
Wyndham Business Place
Tisbury
Wiltshire
SP3 6GS
08443 511115